

Established in 1988, FORTWORTH has been engaged in development and manufacture of boring and milling machine in Taiwan for many years.
All our boring and milling machines are designed and manufactured with the finest craftsmanship for maximum accuracy, stability and processing.



FORTWORTH



FORTWORTH

昌鑫機械工業股份有限公司
CHUNG SING MACHINERY CO., LTD.

429 台灣 台中市神岡區豐工三路1號
NO.1, FENGGONG 3RD RD., SHENGANG DIST.,
TAICHUNG CITY 429, TAIWAN
TEL: 886-4-25252723 FAX: 886-4-25270957

E-mail: csmill@ms27.hinet.net

<http://www.chungsing.com>

VERTICAL / HORIZONTAL BORING & MILLING MACHINE
床 型 立 橫 搪 銑 床

FORTWORTH... Invincible!

**As invincible as a fortress,
you can rely on "FORTWORTH"**

OUR GROWTH



Factory in 1988



New Headquarter and factory in 2014

Awarded Certificates

- 2016 > Certificate approved CE by Safenet Limited, U.K
- 2013 > Certificate approved ISO9001: 2008 by AMTRI VERITAS, England
- 2011 > Certificate approved ISO9001: 2008 by AMTRI VERITAS, England
- 2007 > Certificate approved ISO9001: 2000 by AMTRI VERITAS, England
- 2004 > Certificate approved ISO9001: 2000 by AMTRI VERITAS, England
- 2000 > Certificate approved ISO 9002 by AMTRI VERITAS, England
- 1999 > Certificate approved EEC by TUV Rhineland, Germany

BED TYPE VERTICAL BORING & MILLING MACHINE

床型立式搪銑床

CS-VBM-3V-A

- 工作台進給系統用大功率的伺服馬達，確保工作台進給平順穩定，變速操作更簡單容易。
- 主軸頭上下移動配置有手動快移及微調功能，並且擁有自動進給搪孔及鑽孔功能。
手動三叉桿位於主軸頭前方，可快速操作刀具工作點的設定。
- Table feeding system equipped with powerful servo motor, ensure the table movement smoothly and operating more easily.
- A manual rapid feed and fine feed on the vertical head, it is also equipped with power feed for boring and drilling. A tri-lever handle mounted in the front easy operation to perform manual rapid movement of the head and easy to setup tool position.

SPECIFICATION 規格表

1 容量 CAPACITY			
工作台行程 (左右)	Table travel (Longitudinal)	1,000 (39-3/8)	mm(in)
工作台行程 (前後)	Table travel (Cross)	380 (14-15/16)	mm(in)
立主軸頭行程 (Z軸)	Spindle head travel (Vertical)	500 (19-11/16)	mm(in)
主軸端至工作台面距離	Spindle nose to table top	100~600(3-15/16~23-5/8)	mm(in)
主軸中心至機身面距離	Spindle center to column	380 (14-15/16)	mm(in)
2 工作台 TABLE			
工作台面尺寸 (長 X 寬)	Table working area	1,700 x 380 (67 x 14-15/16)	mm(in)
T 形槽 (寬 X 數 X 距)	T slot (Wide x No. x Pitch)	18x5x70 (0.709 x 5 x 2-3/4)	mm(in)
工作台面高度	Table top to floor	800 (31-1/2)	mm(in)
3 主軸頭 SPINDLE HEAD			
主軸鼻端	Spindle nose	ISO R297 No.50	
主軸轉速	Spindle speed	45~1,500 (60Hz)	rpm
主軸段數	No. of spindle speed	12	steps
主軸頭進給速度	Feeds (Vertical spindle)	0.05~0.2 (0.002~0.008)	mm/rev (ipr)
4 進給 / 快移速率 FEED / RAPID			
快速進給 (左右, 前後)	Rapid traverse (Longitudinal & cross)	2,800 (110)	mm/min(ipm)
進給速度 (左右, 前後)	Feed rates (Longitudinal & cross)	28~1,000 (1-1/8~39-3/8)	mm/min(ipm)
進給段數	Change of feeds	無段 Infinitely variable	steps
5 電動機 MOTORS			
主軸	Spindle	5.5 (7.5)-4P	kW(HP)
XY軸進給 (伺服馬達)	Feed of X, Y axis	1.3 (1.74) servo motor	kW(HP)
潤滑	Lubrication	3.5W- 2P	
切削液	Cutting fluid	0.1 (1/8) - 2P	kW(HP)
6 機械尺寸 MACHINE SIZE			
機器高度	Machine height	2,410 (94-7/8)	mm(in)
佔地面積 (左右 X 前後)	Floor space (Longitudinal x cross)	3,200x1,960 (126x78)	mm(in)
重量 (約)	Net weight (Approx.)	4,000 (8,800)	kg(lbs)
標準色	Standard color	灰色 Gray	

由於不斷的研究發展改進，機械設計及規格如有更改，恕不另行通知。
All specification and designs are subject to change without notice.

標準附件 STANDARD ACCESSORIES

1. 切削液裝置	Cutting Fluid Device	1 unit
2. 調整工具	Tools And Box	1 set
3. 水平調整塊	Levelling Blocks	6 pcs
4. 水平調整螺栓及螺帽	Levelling Bolts and Nuts	6 sets
5. 拉桿	Draw Bar	1 pce

特殊附件 OPTIONAL ACCESSORIES

1. 數字讀取裝置	Digital read out
2. 自動拉刀裝置	Power draw bar

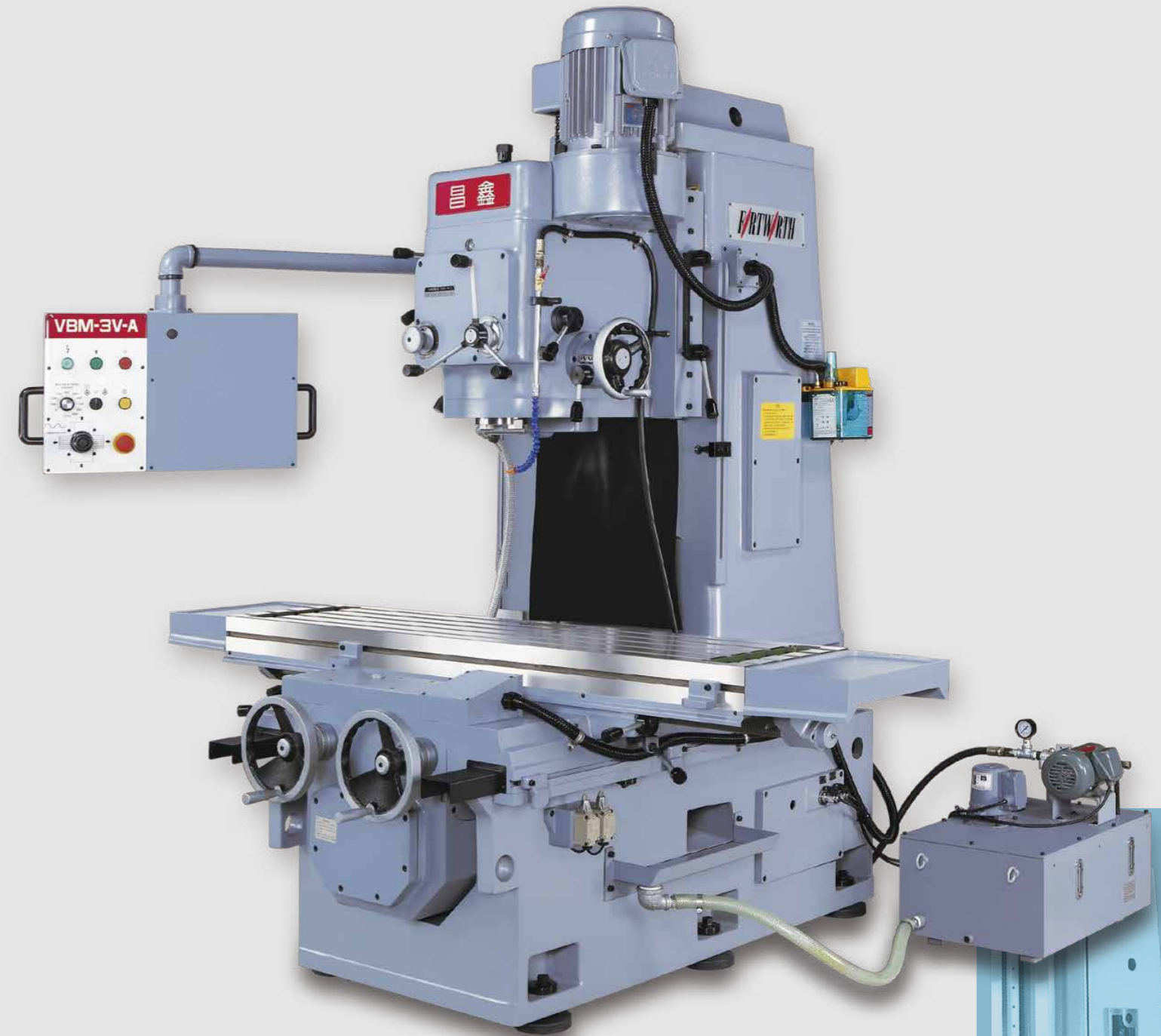

結構堅強的機體 RIGID STRUCTURE

機身與底座為箱型結構，並採用特殊的加強肋設計，整體構造堅強、穩重，適合重力切削。
Box-shaped column and base reinforced by ribs with a strong and rigid construction which fits to do heavy cutting.

BED TYPE VERTICAL BORING & MILLING MACHINE

床型立式搪銑床

CS-VBM-4V



集中配置的操作桿

整體構造簡單，手輪等全部集中配置於機器前面操作性良好，保養容易。

OPERATOR CONTROLS

All controls are centralized for operator's convenience.

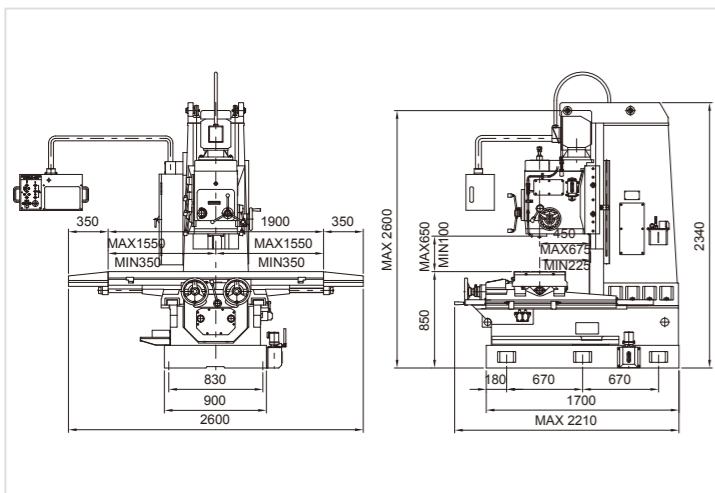

SPECIFICATION 規格表

1 容量 CAPACITY

工作台行程(左右)	Table travel(Longitudinal)	1,200(47-1/4)	mm(in)
工作台行程(前後)	Table travel(cross)	450(17-11/16)	mm(in)
立銑頭行程(上下)	Vertical spindle head travel(vertical)	550(21-5/8)	mm(in)
立主軸端至工作台面距離	Vertical spindle nose to table top	100-650(3-15/16~25-5/8)	mm(in)
立主軸中心至機身距離	Vertical spindle center to column front	450(17-11/16)	mm(in)

2 工作台 TABLE

工作台面尺寸	Table working area	1,900x450(74-13/16x17-11/16)	mm(in)
T型槽(寬x數x距)	T slot (Wide x No. x Pitch)	18x5x80(0.709x5x3-1/8)	mm(in)
工作台面高度	Table top to floor	850(33-1/2)	mm(in)

3 主軸頭 SPINDLE HEAD

主軸鼻端	Spindle nose	ISO R297 No.50	
立主軸轉速	Vertical spindle speeds	45-1,500(60HZ)	rpm
立主軸段數	No. of Vertical spindle speed	12	steps
進給速度(立主軸)	Feeds (vertical spindle)	0.05-0.2(0.002-0.008)	mm/rev.(pr)

4 進給速度 FEED / RAPID

快速進給(左右和前後)	Rapid traverse (Longitudinal & cross)	2,880(113-3/8)(60HZ)	mm/min(ipm)
進給速度(左右和前後)	Feed rates (Longitudinal & cross)	28-875(1-1/8~34-7/16)(60HZ)	mm/min(ipm)
進給段數	Change of feeds	12	steps

5 電動機 MOTORS

立主軸	Vertical spindle	AC 7.5(10)-4P	kW(HP)
進給	Feed	AC 1.5(2)-4P	kW(HP)
潤滑	Lubrication	AC 3.5W-2P	kW(HP)
切削液	Cutting fluid	AC 0.12(1/6)-2P	kW(HP)

6 機械尺寸 MACHINE SIZE

機器高度	Machine height	2,600(102-3/8)	mm(in)
佔地面積(左右x前後)	Floor space (Longitudinal x cross)	3,800x2,210(150x87)	mm(in)
重量(約)	Net weight (Approx.)	5,200(11,440)	kg(lbs)
標準色	Standard color	灰色 Gray	

由於不斷的研究發展改進，機械設計及規格如有更改，恕不另行通知。
All specification and designs are subject to change without notice.

標準附件 STANDARD ACCESSORIES

1. 切削液裝置	Cutting Fluid Device	1 unit
2. 調整工具	Tools And Box	1 set
3. 水平調整塊	Levelling Blocks	6 pcs
4. 水平調整螺栓及螺帽	Levelling Bolts and Nuts	6 sets
5. 拉桿	Draw Bar	1 pce

特殊附件 OPTIONAL ACCESSORIES

1. 數字讀取裝置	Digital read out
2. 自動拉刀裝置	Power draw bar

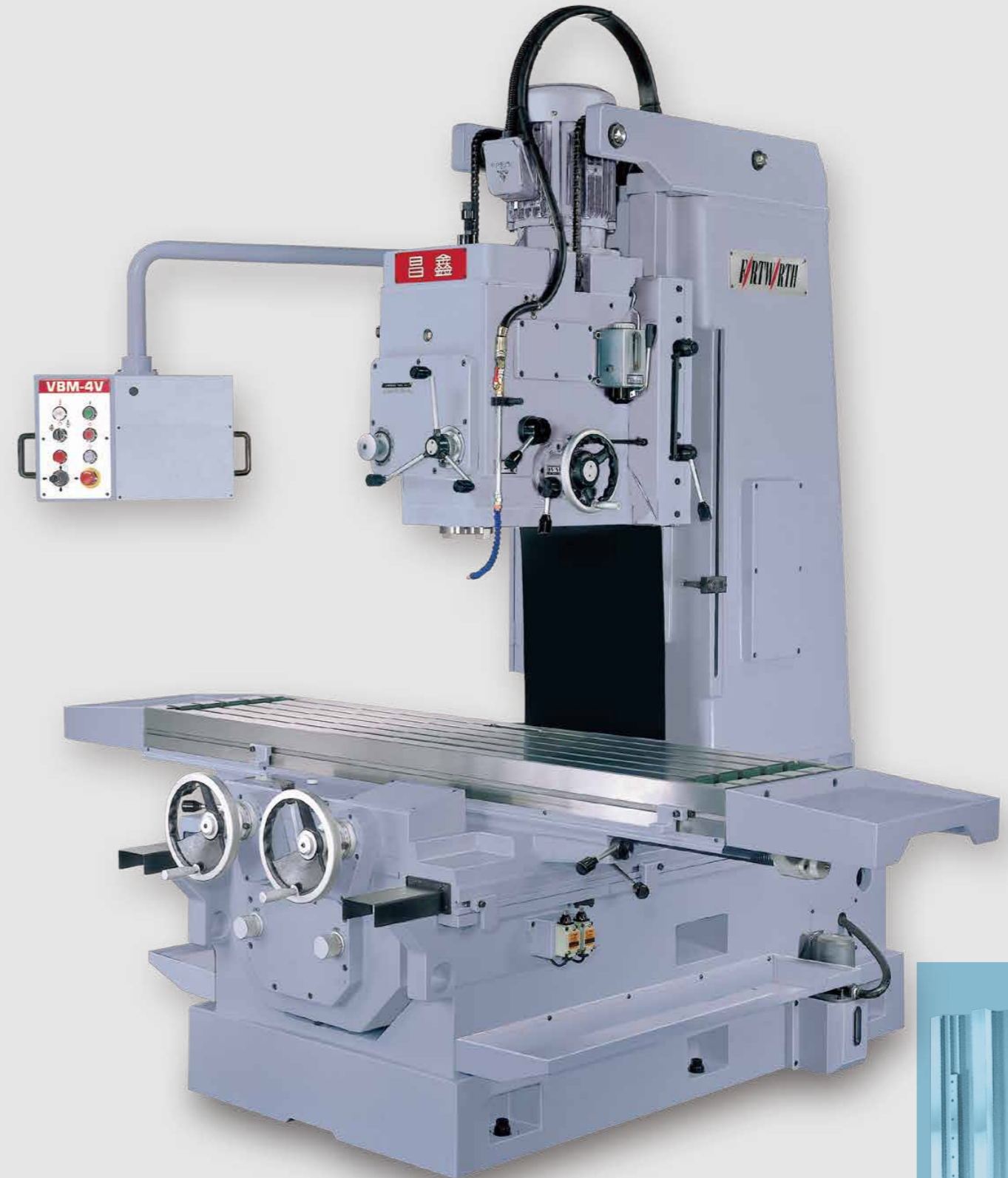

結構堅強的機體 RIGID STRUCTURE

機身與底座為箱型結構，並採用特殊的加強肋設計，整體構造堅強、穩重，適合重力切削。
Box-shaped column and base reinforced by ribs with a strong and rigid construction which fits to do heavy cutting.

BED TYPE VERTICAL BORING & MILLING MACHINE

床型立式搪銑床

CS-VBM-5VL



X軸加2輔助軌道，行程增長至2000mm(選配)
X-Axis up to 2000mm with 2 supporters on request

電器控制系統

CS-VBM-5VL除了機械結構和性能優越之外，本機械採用超高性能變頻器，使工作台可無段變速移動，操作控制更為簡便，驅動穩定品質優異。

ELECTRICAL CONTROL SYSTEM

Inverter is used in the CS-VBM-5VL for table moving with variable speed control.

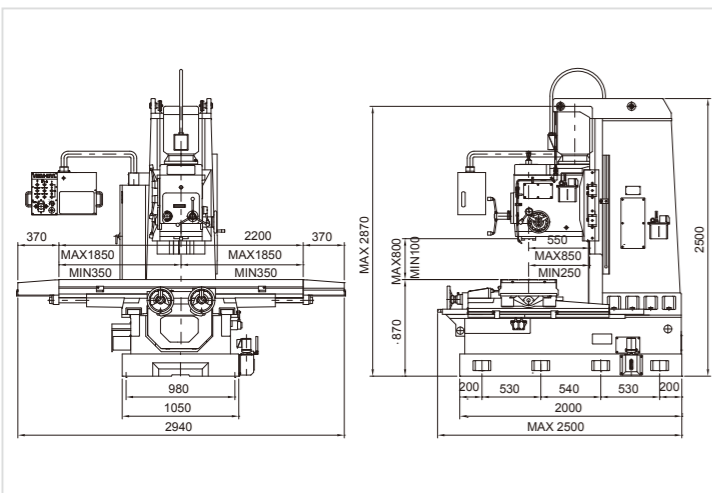

SPECIFICATION 規格表

1 容量 CAPACITY			
工作台行程(左右)	Table travel(Longitudinal)	1,500(59)	mm(in)
工作台行程(前後)	Table travel(cross)	600(23-5/8)	mm(in)
立銑頭行程(上下)	Vertical spindle head travel(vertical)	700(27-9/16)	mm(in)
立主軸端至工作台面距離	Vertical spindle nose to table top	100-800(3-15/16~31-1/2)	mm(in)
立主軸中心至機身面距離	Vertical spindle center to column front	550(21-5/8)	mm(in)
2 工作台 TABLE			
工作台面尺寸	Table working area	2,200x500(86-5/8x19-11/16)	mm(in)
T型槽(寬x數x距)	T slot (Wide x No. x Pitch)	18x5x90(0.709x5x3-9/16)	mm(in)
工作台面高度	Table top to floor	870(34-1/4)	mm(in)
3 主軸頭 SPINDLE HEAD			
主軸鼻端	Spindle nose	ISO R297 No.50	
立主軸轉速	Vertical spindle speeds	45-1,500(60HZ)	rpm
立主軸段數	No. of Vertical spindle speed	12	steps
進給速度(立主軸)	Feeds (vertical spindle)	0.05-0.2(0.002-0.008)	mm/rev.(ipr)
4 進給速度 FEED / RAPID			
快速進給(左右和前後)	Rapid traverse (Longitudinal & cross)	3,300(129-7/8)	mm/min(ipm)
進給速度(左右和前後)	Feed rates (Longitudinal & cross)	28-1,000(1 1/8~39 3/8)	mm/min(ipm)
進給段數	Change of feeds	無段infinitely variable	
5 電動機 MOTORS			
立主軸	Vertical spindle	AC 11(15)-4P	kW(HP)
進給	Feed	AC 1.5(2)-6P	kW(HP)
潤滑	Lubrication	AC 3.5W-2P	
切削液	Cutting fluid	AC 0.12(1/6)-2P	kW(HP)
6 機械尺寸 MACHINE SIZE			
機器高度	Machine height	2,870(113)	mm(in)
佔地面積(左右x前後)	Floor space (Longitudinal x cross)	4,440x2,500(174-7/8x100-3/8)	mm(in)
重量(約)	Net weight (Approx.)	7,000(15,400)	kg(lbs)
標準色	Standard color	灰色 Gray	

由於不斷的研究發展改進，機械設計及規格如有更改，恕不另行通知。
All specification and designs are subject to change without notice.

標準附件 STANDARD ACCESSORIES

1. 切削液裝置	Cutting Fluid Device	1 unit
2. 調整工具	Tools And Box	1 set
3. 水平調整塊	Levelling Blocks	8 pcs
4. 水平調整螺栓及螺帽	Levelling Bolts And Nuts	8 sets
5. 拉桿	Draw Bar	1 pce

特殊附件 OPTIONAL ACCESSORIES

1. 數字讀取裝置	Digital read out
2. 自動拉刀裝置	Power draw bar

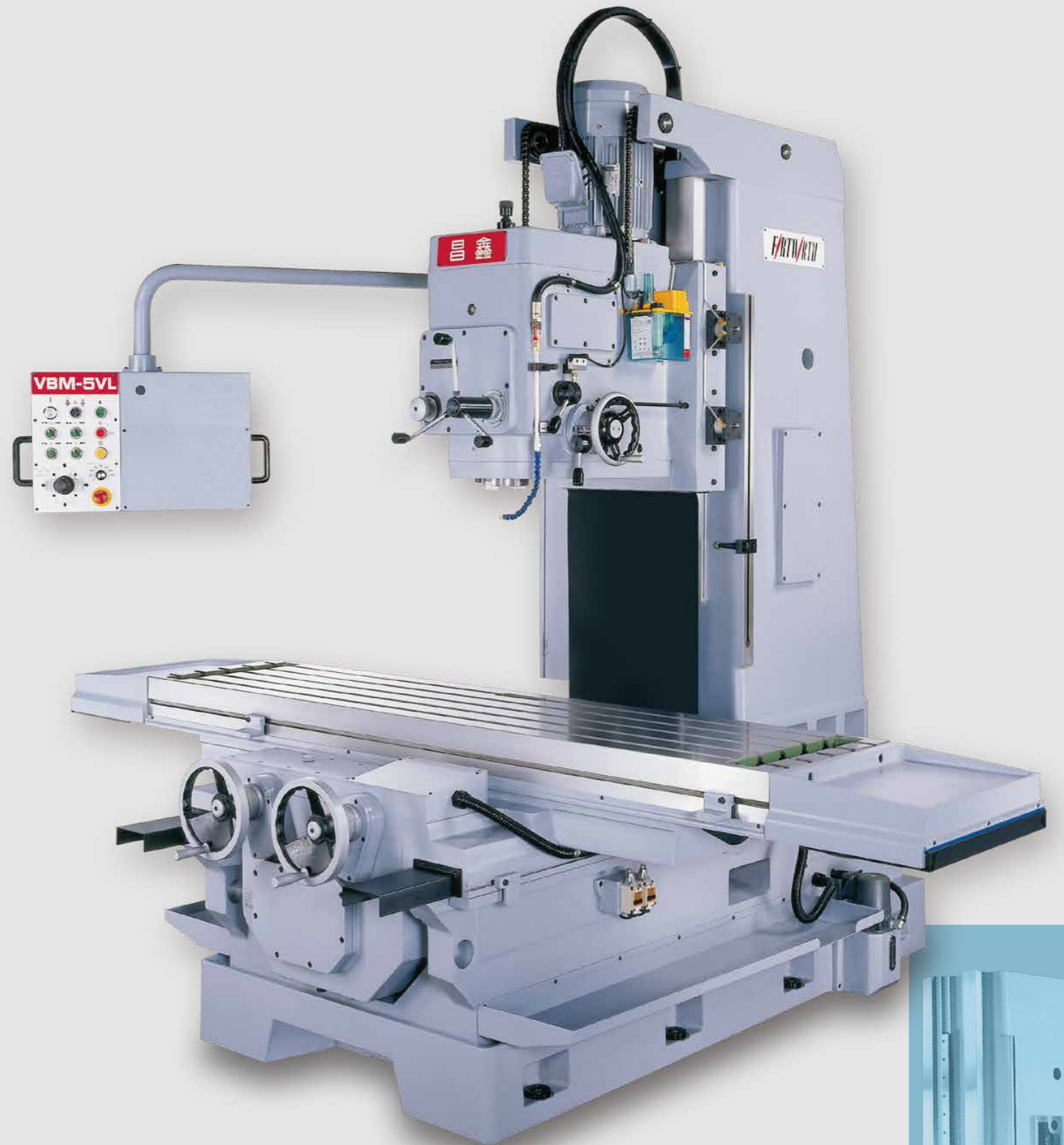

結構堅強的機體 RIGID STRUCTURE

機身與底座為箱型結構，並採用特殊的加強肋設計，整體構造堅強、穩重，適合重力切削。
Box-shaped column and base reinforced by ribs with a strong and rigid construction which fits to do heavy cutting.

BED TYPE VERTICAL WITH HORIZONTAL BORING & MILLING MACHINE

床型立橫搪銑床

CS-VBM-5VHL

- CS-VBM-5VHL的X、Y和W軸使用鋼珠導螺桿及AC伺服馬達驅動，使進給可用快速、自動及手動等三種方法。
- 立主軸、鞍座及工作台使用油氣壓鎖緊裝置。
- 橫主軸轉速為40~1450RPM及12段變速。
- 主軸頭平衡配重，使頭部移動平滑及維持長時間之精度。
- X軸行程可增長至2000mm(選配)。
- The X, Y and W axis of CS-VBM-5VHL are equipped with ballscrew and AC servo motor.
- There are three functions: Rapid & Jog & Manual feed.
- The vertical spindle head, saddle and table are equipped with pneumatic clamp device.
- The horizontal spindle speed is 40-1450 RPM and with 12 steps speed changes.
- A counter weight balance permits the head to travel smoothly and to retain its accuracy stability.
- The X-axis travel could be extended up to 2000mm on request.



SPECIFICATION 規格表

1 容量 CAPACITY			
工作台行程(左右)	Table travel(Longitudinal)	1,500(59)	mm(in)
工作台行程(前後)	Table travel(cross)	600(23-5/8)	mm(in)
立銑頭行程(上下)	Vertical spindle head travel(vertical)	700(27-9/16)	mm(in)
橫銑頭行程(上下)	Horizontal spindle head travel(vertical)	650(25-9/16)	mm(in)
立主軸端至工作台距離	Vertical spindle nose to table top	100-800(3-15/16~31-1/2)	mm(in)
立主軸中心至機身距離	Vertical spindle center to column front	550(21-5/8)	mm(in)
橫主軸中心與立主軸中心距離	Distance between Horizontal & vertical spindle center	550(21-5/8)	mm(in)
2 工作台 TABLE			
工作台尺寸	Table working area	2,200x500(86-5/8x19-11/16)	mm(in)
T型槽(寬x數x距)	T slot (Wide x No. x Pitch)	18x5x90(0.709x5x3-9/16)	mm(in)
工作台高度	Table top to floor	870(34-1/4)	mm(in)
3 主軸頭 SPINDLE HEAD			
主軸鼻端	Spindle nose	ISO R297 No.50	
立主軸轉速	Vertical spindle speeds	45-1,500(60HZ)	rpm
橫主軸轉速	Horizontal spindle speeds	40-1,450(60HZ)	rpm
立主軸段數	No. of Vertical spindle speed	12	steps
橫主軸段數	No. of Horizontal spindle speed	12	steps
進給速度(立主軸)	Feeds (vertical spindle)	0.05-0.2(0.002-0.008)	mm/rev(ipr)
4 進給速度 FEED / RAPID			
快速進給(左右和前後)	Rapid traverse(longitudinal & cross)	3,300(129-7/8)(60HZ)	mm/min(ipm)
橫主軸快速進給(上下)	W axis rapid traverse (Vertical)	3,800(150)(60HZ)	mm/min(ipm)
進給速度(左右和前後)	Feed rates(longitudinal & cross)	28-1,000(1 1/8~39 3/8)(60HZ)	mm/min(ipm)
橫主軸進給速度(上下)	Horizontal feed rates (Vertical)	28-1,000(1 1/8~39 3/8)(60HZ)	mm/min(ipm)
進給段數	Change of feeds	無段indefinitely variable	steps
5 電動機 MOTORS			
立主軸	Vertical spindle	AC 11(15)-4P	kW(HP)
橫主軸	Horizontal spindle	AC 5.5(7.5)-6P	kW(HP)
進給(伺服馬達)	Feed	Servo Motor	
		X & Y axis: 3.5(4.7)	kW(HP)
		W axis: 0.85(1.14)	kW(HP)
潤滑	Lubrication	AC 3.5W-2P	
切削液	Cutting fluid	AC 0.12(1/6)-2P	kW(HP)
6 機械尺寸 MACHINE SIZE			
機器高度	Machine height	2,870(113)	mm(in)
佔地面積(左右x前後)	Floor space (Longitudinal x cross)	4,440x2,500(174-7/8x100-3/8)	mm(in)
重量(約)	Net weight (Approx.)	8,700(19,140)	kg(lbs)
標準色	Standard color	灰色 Gray	

由於不斷的研究發展改進，機械設計及規格如有更改，恕不另行通知。
All specification and designs are subject to change without notice.

標準附件 STANDARD ACCESSORIES

1. 切削液裝置	Cutting Fluid Device	1 unit
2. 調整工具	Tools And Box	1 set
3. 水平調整塊	Levelling Blocks	8 pcs
4. 水平調整螺栓及螺帽	Levelling Bolts And Nuts	8 sets
5. 拉桿	Draw Bar	1 pce

特殊附件 OPTIONAL ACCESSORIES

1. 數字讀取裝置	Digital read out
2. 自動拉刀裝置	Power draw bar

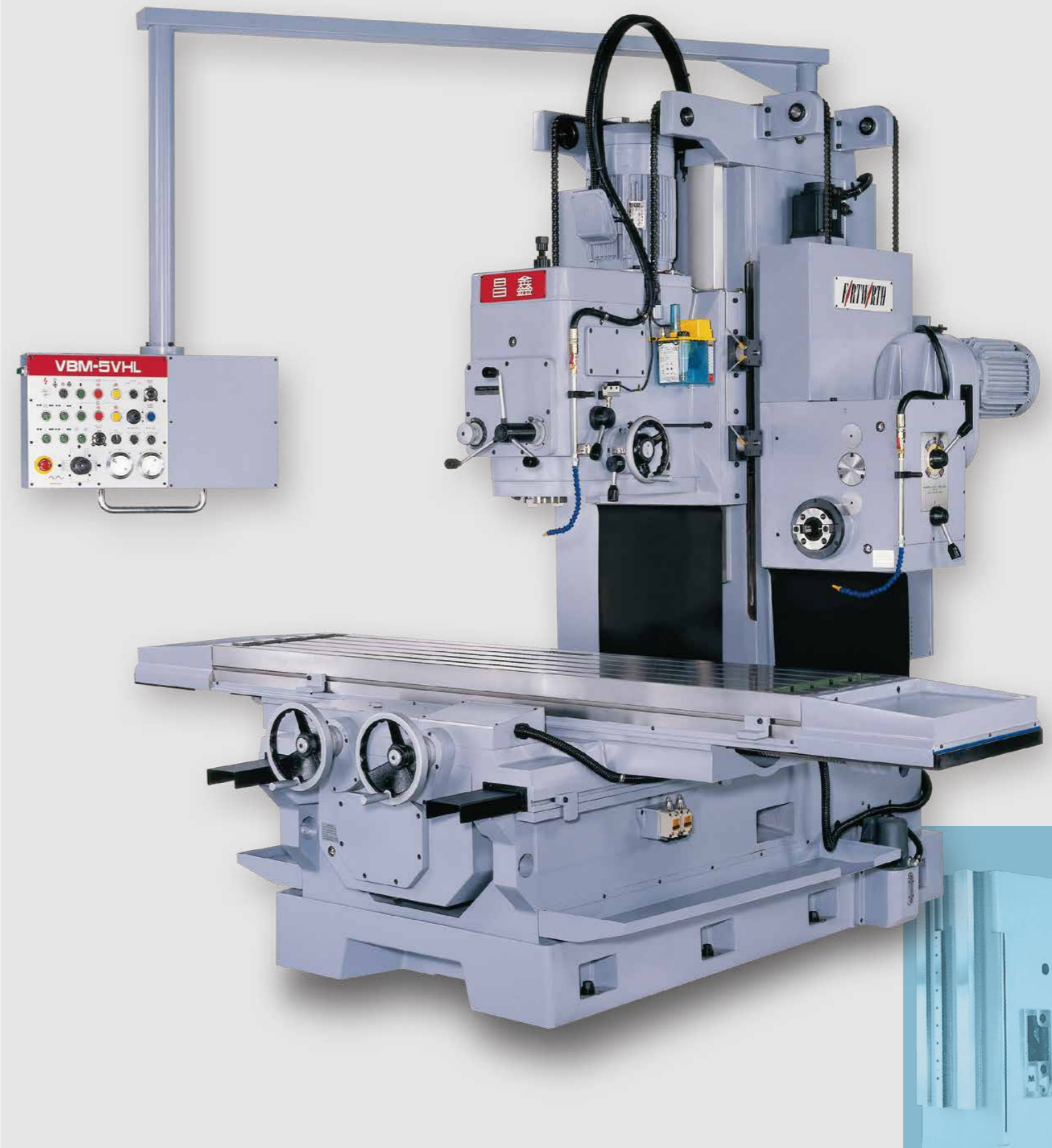

結構堅強的機體 RIGID STRUCTURE

機身與底座為箱型結構，並採用特殊的加強肋設計，整體構造堅強、穩重，適合重力切削。
Box-shaped column and base reinforced by ribs with a strong and rigid construction which fits to do heavy cutting.

BED TYPE VERTICAL BORING & MILLING MACHINE

床型立式搪銑床

CS-VBM-8VL

- 主軸二段式齒輪，配合高性能變頻器無段變速，扭力輸出大，操控方便。
- XY軸採用滾珠螺桿及大馬力的伺服馬達驅動，工作台移動平穩穩定。
- 立銑頭、鞍座及工作台使用氣-油壓鎖緊裝置。
- X軸可選配附2輔助軌道，行程增長至2500mm。
- Full geared drive spindle with 2-ranges variable speed, powerful and easy operating.
- Table feeding system equipped with precision ballscrews and powerful servo motor ensure the table movement smoothly.
- The XYZ axis equipped with pneumatic clamp device.
- The X axis could be extended up to 2500mm with 2 sub-slideway on request.

SPECIFICATION 規格表

1 容量 CAPACITY			
工作台行程 (左右)	Table travel (Longitudinal)	2,000(78-3/4)	mm(in)
工作台行程 (前後)	Table travel (Cross)	800(31-1/2)	mm(in)
主軸頭行程 (上下)	Vertical spindle head travel (Vertical)	700(27-9/16)	mm(in)
主軸鼻端至工作台面距離	Vertical spindle nose to table top	70-770(2-3/4~30-1/4)	mm(in)
主軸中心至機身面距離	Vertical spindle center to column	800(31-1/2)	mm(in)
2 工作台 TABLE			
工作台尺寸	Table working area	2,700 x 750(106-1/4x29-1/2)	mm(in)
T型槽	T slot (Wide x No. x Pitch)	18 x 5 x150(0.7x5x5.9)	mm(in)
工作台面高度	Table top to floor	900(35-7/16)	mm(in)
3 主軸頭 SPINDLE HEAD			
主軸銜孔	Spindle nose	ISO R297 No.50	
主軸轉速 (無段)	Vertical spindle speed	45-1,500 / Infinitely variable	rpm
進給速率 (立主軸)	Z-axis feeds (Vertical spindle)	3-300(0.12~11.81)	mm/min(ipm)
4 進給速度 FEED / RAPID			
快速移位速率 (左右/前後)	Rapid traverse (Longitudinal & cross)	3,100(122)	mm/min(ipm)
進給速率 (左右/前後)	Feed rates (Longitudinal & cross)	28-1,000(1.1~39.37)	mm/min(ipm)
進給段數	Change of feeds	無段 Infinitely Variable	
5 電動機 MOTORS			
主軸	Vertical spindle	AC 11(15)-4P	kW(HP)
XY軸進給 (伺服)	Feed for X, Y axis	AC 3.5(4.7) servo motor	kW(HP)
Z軸進給 (伺服)	Feed for Z axis	AC 1.3(1.75) servo motor	kW(HP)
自動潤滑單元	Lubrication	AC 3.5W-2P	
切削液	Cutting fluid	AC 0.12(1/6)-2P	kW(HP)
6 機械尺寸 MACHINE SIZE			
機器高度	Machine height	2,923(115)	mm(in)
佔地面積 (左右x前後)	Floor space (Longitudinal x cross)	5,694 x 3,075(224-3/16x121)	mm(in)
重量 (約)	Net weight (Approx.)	11,800(26,000)	kg(lbs)
標準色	Standard color	灰色 Gray	

由於不斷的研究發展改進，機械設計及規格如有更改，恕不另行通知。
All specification and designs are subject to change without notice.

標準附件 STANDARD ACCESSORIES

1. 切削液裝置	Cutting Fluid Device	1 unit
2. 調整工具	Tools And Box	1 set
3. 水平調整塊	Levelling Blocks	10 pcs
4. 水平調整螺栓及螺帽	Levelling Bolts and Nuts	10 sets
5. 拉桿	Draw Bar	1 pce

特殊附件 OPTIONAL ACCESSORIES

1. 數字讀取裝置	Digital read out
2. 自動拉刀裝置	Power draw bar

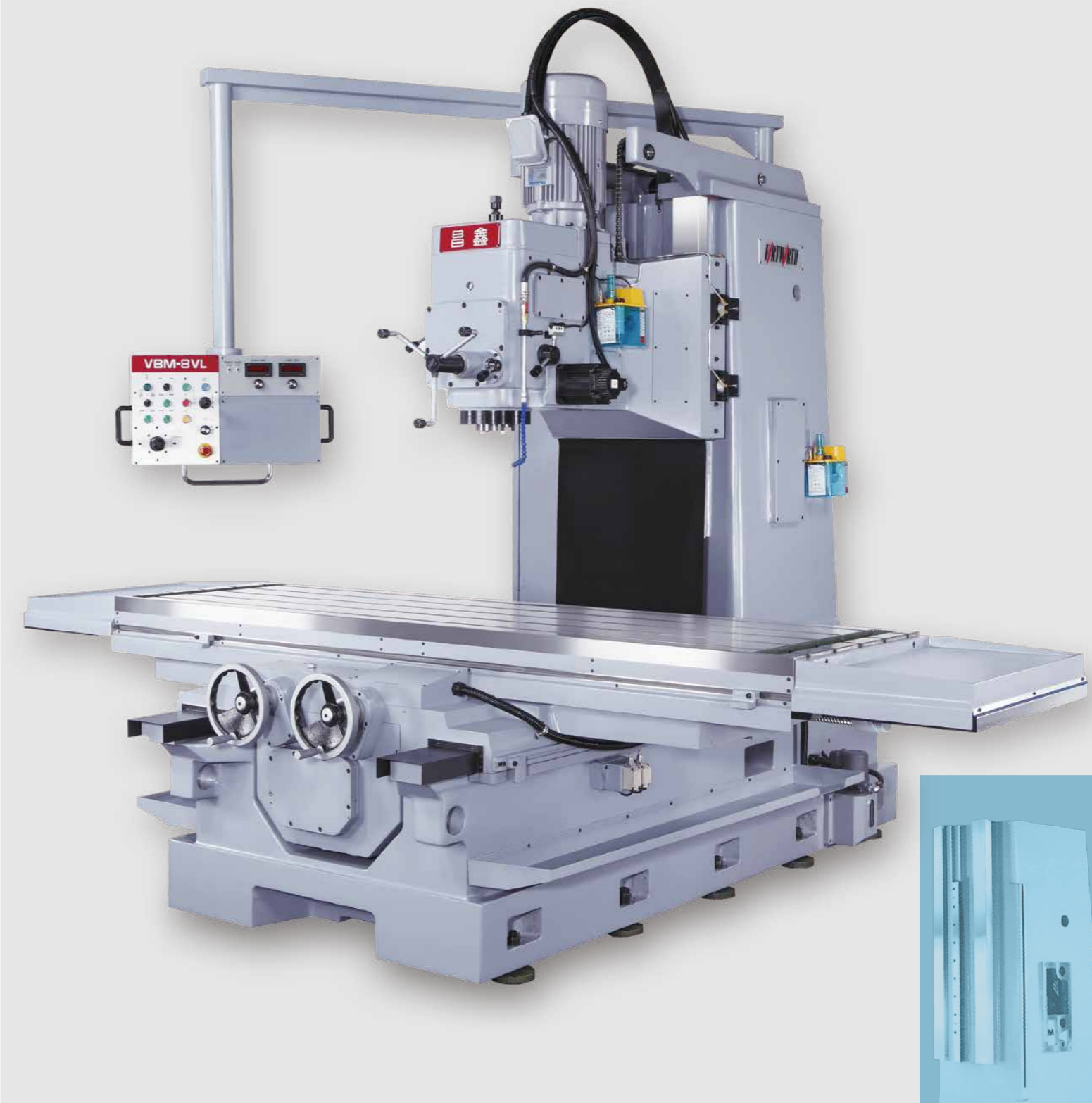

結構堅強的機體 RIGID STRUCTURE

機身與底座為箱型結構，並採用特殊的加強肋設計，整體構造堅強、穩重，適合重力切削。
Box-shaped column and base reinforced by ribs with a strong and rigid construction which fits to do heavy cutting.

BED TYPE VERTICAL WITH HORIZONTAL BORING & MILLING MACHINE

床型立橫搪銑床

CS-VBM-8VHL



X軸加2輔助軌道，行程增長至2500mm(選配)
X-Axis up to 2500mm with 2 supporters on request

- 立主軸二段式齒輪，配合高性能變頻器無段變速，扭力輸出大，操控方便。
- XY軸採用滾珠螺桿及大馬力的伺服馬達驅動，工作台移動平穩穩定。
- 立銑頭，鞍座及工作台使用氣-油壓鎖緊裝置。
- Full geared drive vertical spindle with 2-ranges variable speed, powerful and easy operating.
- Table feeding system equipped with precision ballscrews and powerful servo motor ensure the table movement smoothly.
- The XYZ axis equipped with pneumatic clamp device.

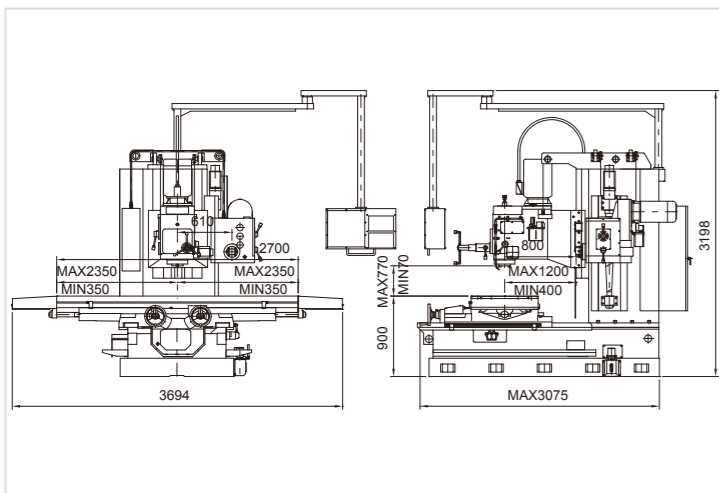

SPECIFICATION 規格表

1 容量 CAPACITY			
工作台行程(左右)	Table travel (Longitudinal)	2,000(78-3/4)(2,500 opt.)	mm(in)
工作台行程(前後)	Table travel (Cross)	800(31-1/2)	mm(in)
立主軸頭行程(Z軸)	Vertical spindle head travel (Z axis)	700(27-9/16)	mm(in)
橫主軸頭行程(W軸)	Horizontal spindle head travel (W axis)	650(25-9/16)	mm(in)
立主軸鼻端至工作台面距離	Vertical spindle nose to table top	70~770(2-3/4~30-1/4)	mm(in)
立主軸中心至機身面距離	Vertical spindle center to column	800(31-1/2)	mm(in)
立橫主軸中心距	Distance between spindle centers	610(24)	mm(in)
2 工作台 TABLE			
工作台尺寸	Table working area	2,700 x 750(106-1/4 x 29-1/2)	mm(in)
T 型槽	T slot (Wide x No. x Pitch)	18 x 5 x 150(0.7 x 5 x 5.9)	mm(in)
工作台面高度	Table top to floor	900(35-7/16)	mm(in)
3 主軸頭 SPINDLE HEAD			
主軸銜孔	Spindle nose	ISO R297 No.50	
立主軸轉速(無段)	Vertical spindle speed	45~1,500rpm/ Infinitely variable	rpm
橫主軸轉速	Horizontal spindle speed	40~1,450rpm (60Hz) / 12 steps	steps
4 進給 / 快移速率 FEED / RAPID			
XY快速移位速率(左右/前後)	Rapid traverse (Longitudinal & cross)	3,100	mm/min
W軸快速移位速率	W axis rapid traverse (Vertical)	3,800	mm/min
XY進給速率(左右/前後)	X, Y axis feed rate (Longitudinal & cross)	28~1,000	mm/min
Z軸進給速率	Z-axis feed (Vertical spindle)	3~300	mm/min
W軸進給速率	W-axis feed rate (Horizontal spindle)	28~1,000	mm/min
進給段數	Change of feeds	無段 Infinitely variable	
5 電動機 MOTORS			
立主軸	Vertical spindle	AC 11(15) -4P	KW (HP)
橫主軸	Horizontal spindle	AC 5.5(7.5) -6P	KW (HP)
進給	XY軸(伺服)	For X, Y axis	AC 3.5(4.7) servo motor
Feed	Z軸(伺服)	For Z axis (Vertical spindle)	AC 1.3(1.75) servo motor
	W軸(伺服)	For W axis (Horizontal spindle)	AC 0.85(1.14)(servo)
自動潤滑單元	Lubrication	AC 3.5W-2P	
切削冷卻裝置	Cutting fluid	AC 0.12(1/6)-2P	KW (HP)
6 機械尺寸 MACHINE SIZE			
機器高度	Machine height	3,198(126)	mm(in)
佔地面積(左右x前後)	Floor space (Longitudinal x cross)	5,694 x 3,075(224-3/16x121)	mm(in)
重量(約)	Net weight (Approx.)	13,000(28,650)	kg(lbs)
標準色	Standard color	灰色 Gray	

由於不斷的研究發展改進，機械設計及規格如有更改，恕不另行通知。
All specification and designs are subject to change without notice.

標準附件 STANDARD ACCESSORIES

- | | | |
|--------------|--------------------------|---------|
| 1. 切削液裝置 | Cutting Fluid Device | 1 unit |
| 2. 調整工具 | Tools And Box | 1 set |
| 3. 水平調整塊 | Levelling Blocks | 10 pcs |
| 4. 水平調整螺栓及螺帽 | Levelling Bolts and Nuts | 10 sets |
| 5. 拉桿 | Draw Bar | 1 pce |

特殊附件 OPTIONAL ACCESSORIES

- | | |
|-----------|------------------|
| 1. 數字讀取裝置 | Digital read out |
| 2. 自動拉刀裝置 | Power draw bar |

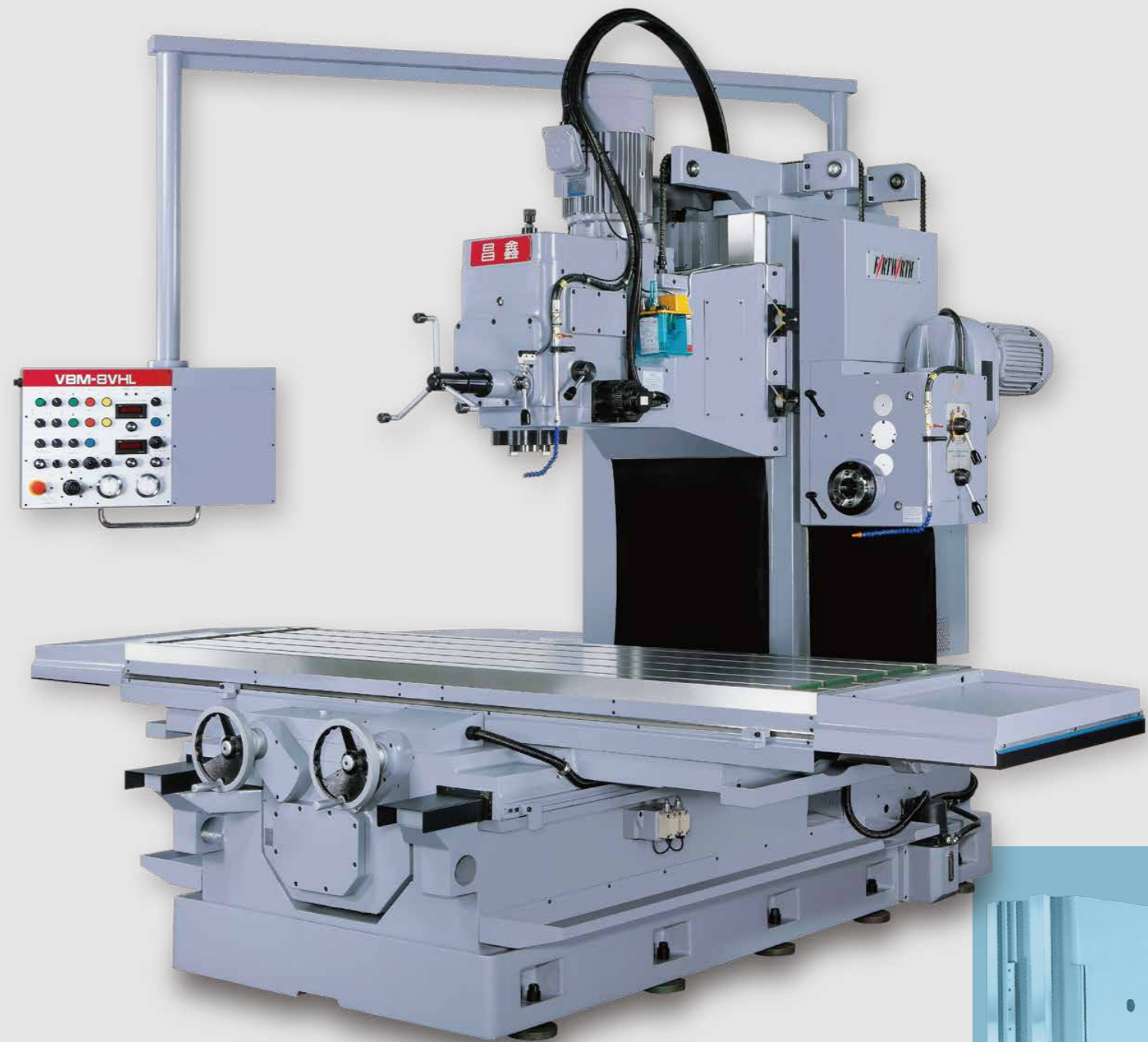

結構堅強的機體 RIGID STRUCTURE

機身與底座為箱型結構，並採用特殊的加強肋設計，整體構造堅強、穩重，適合重力切削。
Box-shaped column and base reinforced by ribs with a strong and rigid construction which fits to do heavy cutting.

HORIZONTAL BORING & MILLING MACHINE

高精度臥式搪銑床

CS-HB-140



電控箱裝置 Electrical Cabinet



分度工作台 Index Table



數字尺顯示器 Digital Read Out



XYZ伺服馬達驅動(選配) 電子手輪(選配)
XYZ with servo motor(option) MPG(option)

- X軸和Z軸使用鋼珠導螺桿，使進給平滑快速。
- 三軸採用油壓鎖緊裝置。
- 主軸頭平衡配重，使頭部移動平滑及維持長時間之精度。
- 機體主要鑄件均採用強韌鑄鐵鑄造。

- The X and Z-axis are equipped with ballscrew, ensure the table movement smoothly.
- Headstock, table and saddle equipped with hydraulic clamp to ensure machining accuracy.
- Spindle headstock balance is accurately taken and a counter weight permits the head to travel smoothly and to retain its accuracy stability.
- All casting is made of high quality cast iron and is stress relieved.

SPECIFICATION 規格表

1 容量 CAPACITY

行程X(左右)	Table travel(X axis)	1400(55-3/32)	mm(in)
行程Y(上下)	Head travel(Y axis)	1200(47-3/16)	mm(in)
行程Z(前後)	Table travel(Z axis)	1100(43-1/4)	mm(in)
主軸中心至工作台面距離	Spindle center to table top	0-1200(0~47-3/16)	mm(in)
主軸端至工作台面距離	Spindle end to table center	255-1355(10~53-1/4)	mm(in)

2 工作台 TABLE

工作台面尺寸	Table size overall	1100x800(43-1/4x31-1/2)	mm(in)
T型槽(寬x數x距)	T slot (WidthNo.x Pitch)	20x7x100(0.78x7x3.9)	mm(in)
最大載重	Table load capacity max.	1400(3090)	kg(lbs)

3 主軸頭 SPINDLE HEAD

主軸鼻端	Spindle nose	ISO R297 No.50	
主軸轉速(60HZ)12段	Spindle speed (60Hz) 12 steps	45-1500(30-1000 opt.)	rpm

4 進給速度 FEED / RAPID

X,Y,Z軸快速進給(60HZ)	X, Y, Z rapid (60Hz)	2880	mm/min
X,Y,Z軸自動進給速度(60HZ)	X, Y, Z auto feed (60Hz)	28-875	mm/min
Z軸進給速度(12段)	Z axis boring feeds (12 steps)	0.028~0.875	mm/rev.

5 電動機 MOTORS

主軸馬達	Spindle motor	AC 7.5(10)-4P	kW(HP)
進給馬達	Feed motor	AC 1.5(2)-4P	kW(HP)
主軸頭循環潤滑馬達	Lube pump for headstock	AC 0.2KW-4P	
軌道自動潤滑馬達	Lube pump for slideways	AC 3.5W-2P	
切削冷卻液馬達	Coolant pump	AC 0.12(1/6)-2P	kW(HP)
軌道夾緊油壓馬達	Hydraulic pump for axis clamp	AC 1.5(2)-4P	kW(HP)

6 機械尺寸 MACHINE SIZE

機器高度	Machine height	2800(110)	mm(in)
佔地面積	Floor space	3616x3600(142-3/16x141-3/4)	mm(in)
重量(約)	Net weight (Approx.)	8400(18520)	kg(lbs)
標準色	Standard color	灰色 Gray	

由於不斷的研究發展改進，機械設計及規格如有更改，恕不另行通知。
All specification and designs are subject to change without notice.

標準附件 STANDARD ACCESSORIES

- | | |
|---|---|
| 1. 滑道自動潤滑裝置
Automatic Lubrication System | 6. X(左右)及Z(前後)軸配用滾珠螺桿
X & Z-axis with ballscrew |
| 2. 切削冷卻液裝置
Coolant System | 7. 主軸正反轉攻牙功能
Tapping function |
| 3. 分度工作台600 x 600mm型, 72
Index Table 600 X 600mm, 72 divisions | 8. X,Y及Z軸油壓鎖緊裝置
X, Y & Z-axis with hydraulic clamp |
| 4. 氣動鎖刀裝置
Air power draw-bar | 9. 調整工具
Tool box with adjustment tools |
| 5. 光學尺及顯示器
With Digital Read Out | 10. 水平調整螺絲及墊塊
Leveling blocks and bolts |

- | | |
|---|------------------------------------|
| 電源開關鈕
Power on/off button | 主軸正反轉選擇鈕
Spindle cw/ccw switch |
| 切削水開關選擇鈕
Coolant on/off switch | 進給方式選擇鈕
Feeding mode switch |
| 三軸油壓鎖開關
3 Axis hydraulic clamp switch | 攻牙功能選擇鈕
Tapping function switch |
| Z軸自動進給/快速搖桿
Joystick for Z-axis feed and rapid | 主軸啟動按鈕
Spindle start button |
| X,Y軸自動進給/快速搖桿
Joystick for X,Y-axis feed and rapid | 主軸停止按鈕
Spindle stop button |
| | 主軸寸動按鈕
Spindle inching button |
| | 緊急停止按鈕
Emergency push button |

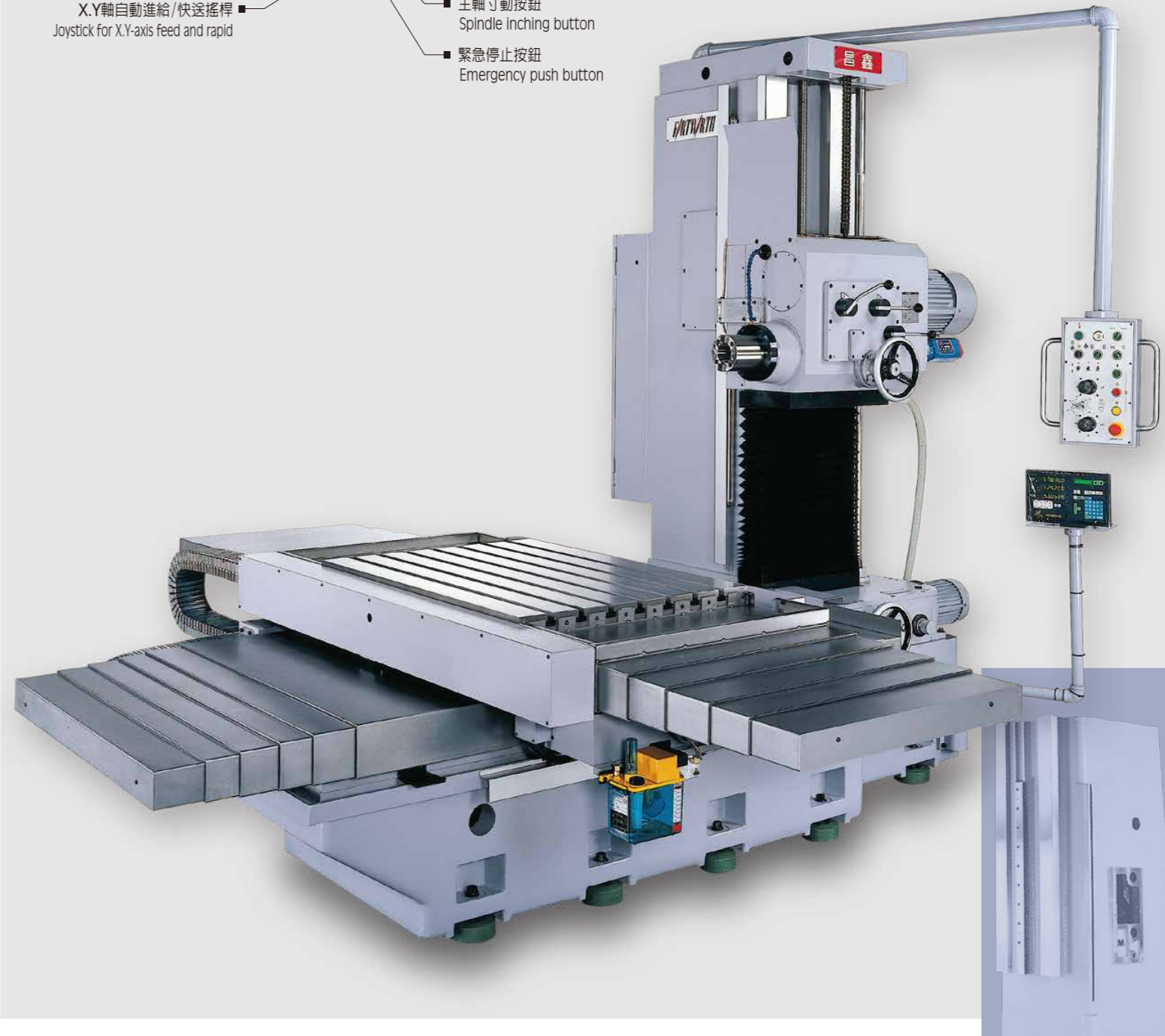

結構堅強的機體 RIGID STRUCTURE

機身與底座為箱型結構，並採用特殊的加強肋設計，整體構造堅強、穩重，適合重力切削。
Box-shaped column and base reinforced by ribs with a strong and rigid construction which fits to do heavy cutting.

HORIZONTAL BORING & MILLING MACHINE

高精度臥式搪銑床

CS-HB-180



電控箱裝置 Electrical Cabinet



分度工作台 Index Table



數字尺顯示器 Digital Read Out



XYZ伺服馬達驅動(標配) 電子手輪(選配)
XYZ with servo motor(standard) MPG(option)

- X軸和Z軸使用鋼珠導螺桿，使進給平滑快速。
- 三軸採用油壓鎖緊裝置。
- 主軸頭平衡配重，使頭部移動平滑及維持長時間之精度。
- 機體主要鑄件均採用強韌鑄鐵鑄造。

- The X and Z-axis are equipped with ballscrew ensure the table movement smoothly.
- Headstock, table and saddle equipped with hydraulic clamp to ensure machining accuracy.
- Spindle headstock balance is accurately taken and a counter weight permits the head to travel smoothly and to retain its accuracy stability.
- All casting is made of high quality cast iron and is stress relieved.

SPECIFICATION 規格表

1 容量 CAPACITY			
行程X(左右)	Table travel(X axis)	1800(70-13/16)	mm(in)
行程Y(上下)	Head travel(Y axis)	1400(55-3/32)	mm(in)
行程Z(前後)	Table travel(Z axis)	1250(49-3/16)	mm(in)
主軸中心至工作台面距離	Spindle center to table top	0-1400(0~55-3/32)	mm(in)
主軸端至工作中心距離	Spindle end to table center	255-1505(10~59-1/4)	mm(in)
2 工作台 TABLE			
工作台尺寸	Table size overall	1500x800(59x32-1/2)	mm(in)
T型槽(寬x數x距)	T slot (WidthxNo.x Pitch)	20x7x100(0.78x7x3.9)	mm(in)
最大載重	Table load capacity max.	2000(4400)	kg(lbs)
3 主軸頭 SPINDLE HEAD			
主軸鼻端	Spindle nose	ISO R297 No.50	
主軸轉速(60HZ)12段	Spindle speed (60Hz) 12 steps	45-1500(30-1000 opt.)	rpm
4 進給速度 FEED / RAPID			
X,Y,Z軸快速進給	X, Y, Z rapid	2800	mm/min
X,Y,Z軸自動進給速度	X, Y, Z auto feed	3-950	mm/min
5 電動機 MOTORS			
主軸馬達	Spindle motor	AC 7.5(10)-4P	kW(HP)
進給馬達	Feed motor	AC servo 2.9(3.8)	kW(HP)
主軸頭循環潤滑馬達	Lube pump for headstock	AC 0.2KW-4P	
軌道自動潤滑馬達	Lube pump for slideways	AC 3.5W-2P	
切削液冷卻馬達	Coolant pump	AC 0.12(1/6)-2P	kW(HP)
軌道夾緊油壓馬達	Hydraulic pump for axis clamp	AC 1.5(2)-4P	kW(HP)
6 機械尺寸 MACHINE SIZE			
機器高度	Machine height	3070(120-13/16)	mm(in)
佔地面積	Floor space	4420x3750(174x147-5/8)	mm(in)
重量(約)	Net weight (Approx.)	11500(25350)	kg(lbs)
標準色	Standard color	灰色 Gray	

由於不斷的研究發展改進，機械設計及規格如有更改，恕不另行通知。
All specification and designs are subject to change without notice.

標準附件 STANDARD ACCESSORIES

- | | |
|--|--|
| 1. 滑道自動潤滑裝置
Automatic Lubrication System | 6. X(左右)及Z(前後)軸配用滾珠螺桿
X & Z-axis with ballscrew |
| 2. 切削冷卻液裝置
Coolant System | 7. 主軸正反轉攻牙功能
Tapping function |
| 3. 分度工作台800 x 800mm型, 72D
Index Table 800 X 800Mm, 72 divisions | 8. X, Y及Z軸油壓鎖緊裝置
X, Y & Z-axis with hydraulic clamp |
| 4. 氣動鎖刀裝置
Air power draw-bar | 9. 調整工具
Tool box with adjustment tools |
| 5. 光學尺及顯示器
With Digital Read Out | 10. 水平調整螺絲及墊塊
Leveling blocks and bolts |

- 主軸正反轉選擇鈕
Spindle cw/ccw switch
- XYZ軸進給速率顯示
XYZ feed speed monitor
- 攻牙功能選擇鈕
Tapping function switch
- 主軸啟動按鈕
Spindle start button
- 主軸停止按鈕
Spindle stop button
- 主軸寸動按鈕
Spindle inching button
- XYZ軸進給速率調整鈕
XYZ feed speed adjusting knob
- 緊急停止按鈕
Emergency push button
- 電源開關鈕
Power on/off button
- 切削水開關選擇鈕
Coolant on/off switch
- 三軸油壓鎖緊開關
3 Axis hydraulic clamp switch
- Z軸自動進給/快速搖桿
Joystick for Z-axis feed and rapid
- X,Y軸自動進給/快速搖桿
Joystick for X,Y-axis feed and rapid

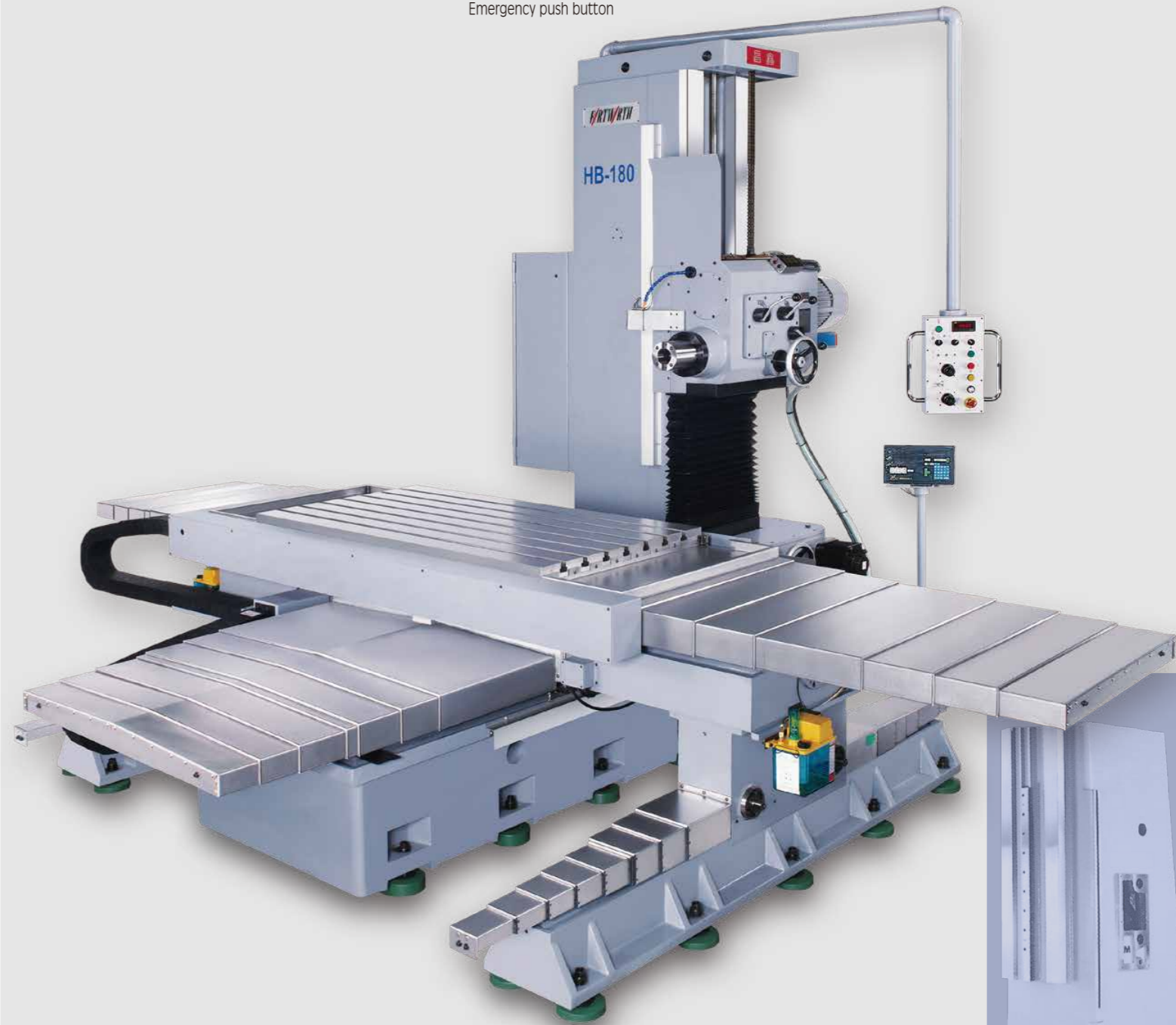

結構堅強的機體 RIGID STRUCTURE

機身與底座為箱型結構，並採用特殊的加強肋設計，整體構造堅強、穩重，適合重力切削。
Box-shaped column and base reinforced by ribs with a strong and rigid construction which fits to do heavy cutting.